

Minifix Flap hinge

Opening angle 90°



Flap made of wood, application example with Fall-Ex flap stay with braking mechanism



Flap with aluminium frame, application example with Fall-Ex flap stay with braking mechanism

- Material: Zinc alloy
- Finish: Nickel plated

Application

- The flap hinges are mounted with the Minifix 15 connector housing
- Quick and easy mounting through drilling from the front
- High stability as the connecting bolt and the hinge were made in one casting
- LGA tested in accordance with DIN 68841

→ For wooden flaps

For press fitting



Detail view: Flap made of wood



Drilling pattern wooden flap

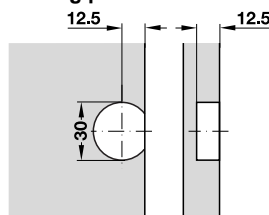

Installation

- Push flap hinge into drilled hole of flap
- Fixing through inner side of cup with countersunk chipboard screw $\varnothing 3.5 \times 20$ mm

Application and planning dimensions

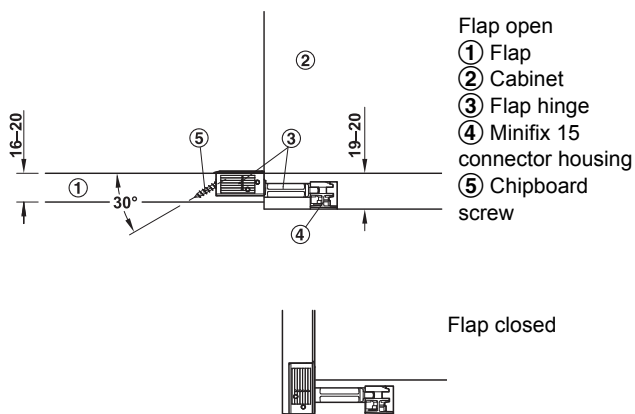

Installation	Cat. No.
For press fitting	342.77.700

Packing: 100 pieces

Order reference

Please order Minifix 15 connector housing and chipboard screws separately.